

(Those who may wish to study The Revelation in more detail may do so from the tract, *To the Seven Churches*. The subject of the Seven Trumpets, however, complete in every detail, you will find in Tract 5, *The Final Warning*.)

To graphically and chronologically illustrate what I have tried to present to you, I shall let you now study it at your leisure through the aid of the chart on the following page.

The twenty-second chapter describes the throne of God and the river of life, and closes with warnings against those who in their private interpretation add and subtract in order to construct their theories. The restriction against adding and subtracting shows that the Revelation is complete as it is, that it needs not man's wisdom, nor his help. If they violate this command, God shall take away their part out of the book of life.

The twenty-first chapter pictures the earth made new and the new Jerusalem.

From these we see that where chapter nineteen leaves off, chapter twenty begins.

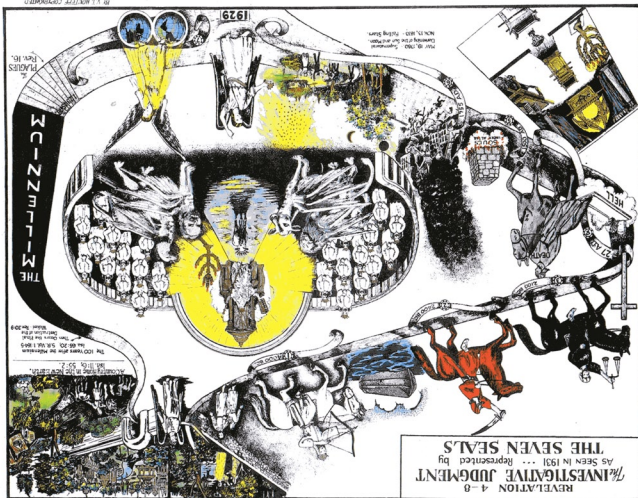

that sat on him was Death, and Hell followed with him. And power was given unto them over the fourth part of the earth, to kill with sword, and with hunger, and with death, and with the beasts of the earth. And when he had opened the fifth seal, I saw under the altar the souls of them that were slain for the Word of God, and for the testimony which they held: and they cried with a loud voice, saying, How long, O Lord, holy and true, dost Thou not judge and avenge our blood on them that dwell on the earth? And white robes were given unto every one of them; and it was said unto them, that they should rest yet for a little season, until their fellowseruants also and their brethren, that should be killed as they were, should be fulfilled.

Please Note: You are looking at the first actual print page of this TG, as you will notice the top panels are upside down. After printing, this page will be folded twice and trimmed to an actual tract size page.

This is trim area

This is trim area

trim marks |

The Universal Publishing Association

Tel: 860 798-3672
 email: upa5453@gmail.com

2008 REPRINT



Vol. 2, Nos. 13, 14
 Printed in the United States of America

TIMELY GREETINGS

—The Only Peace of Mind—

Vol. 2 Copyright, 1948 All Rights Reserved V.T. Houteff Nos. 13, 14



WHERE DO THE SEALS AND TRUMPETS BEGIN AND END?

THE CHRONOLOGICAL SETTING OF THE REVELATION CHAPTER BY CHAPTER—THE SUMMARY

THE CHRONOLOGICAL ARRANGEMENT OF THE REVELATION BY CHAPTERS

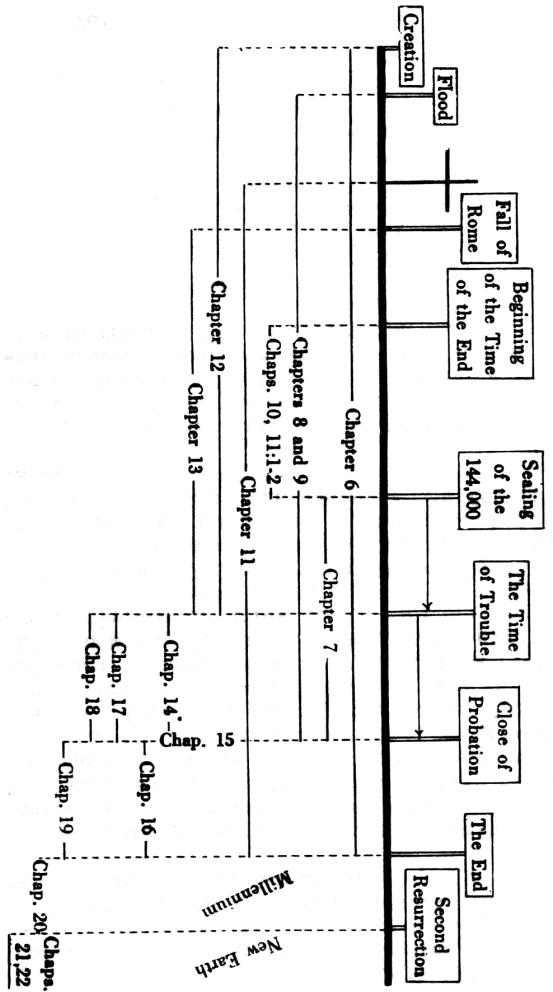

Rev. 6:1-11—And I saw when the Lamb opened one of the seals, and I heard, as it were the noise of thunder, one of the four beasts saying, Come and see. And I saw, and behold a white horse: and he that sat on him had a bow; and a crown was given unto him: and he went forth conquering, and to conquer. And when he had opened the second seal, I heard the second beast say, Come and see. And there went out another horse that was red: and power was given to him that sat thereon to take peace from the earth, and that they should kill one another: and there was given unto him a great sword. And when he had opened the third seal, I beheld, and lo a black horse; and he that sat on him had a pair of balances in his hand. And I heard a voice in the midst of the four beasts say, A measure of wheat for a penny, and three measures of barley for a penny; and thou shalt see the oil and the wine. And when he had opened the fourth seal, I heard the voice of the fourth beast say, Come and see. And I looked, and behold a pale horse: and his name

This afternoon we shall see where each Seal and Trumpet begins and ends. Let us first read the description of the first five seals:

Text of Address by V. T. Houteff,
 Minister of D. Seventh-day Adventists
 Sabbath, November 1, 1947
 Mt. Carmel Chapel
 Waco, Texas

WHERE DO THE SEALS
 AND TRUMPETS BEGIN AND END?

TEXT FOR PRAYER

True Holiness Is Wholeness In Service

I shall read from *Christ's Object Lessons*, page 48, beginning with paragraph 2:

"Many feel a sense of estrangement from God, a realization of their bondage to self and sin; they make efforts for reform; but they do not crucify self. They do not give themselves entirely into the hands of Christ, seeking for divine power to do His will. They are not willing to be molded after the divine similitude. In a general way they acknowledge their imperfections, but they do not give up their particular sins. . . . The only hope for these souls is to realize in themselves the truth of Christ's words to Nicodemus, 'Ye must be born again.' 'Except a man be born from above, he cannot see the kingdom of God.' True holiness is wholeness in the service of God. This is the condition of true Christian living. Christ asks for an unreserved consecration, for undivided service. He demands the heart, the mind, the soul, the strength. Self is not to be cherished. He who lives to himself is not a Christian."

We are commanded here to draw nigh to Christ and depart from self, and that before we can be "born again" we must first die to sin. Let us pray that we may realize that if we feel we are estranged from God, the fault is ours, and that we must do something to remedy the situation; that we must accept Christ's gracious invitation: "Come unto Me, all ye that . . . are heavy laden, and I will give you rest"—Peace.



Thus it is that chapter 12 ends its story with the remnant, the servants of God, the first fruits, the 144,000. They become the remnant after the hypocrites among them are swallowed up. The testimony of Jesus Christ, Inspiration explains, is "the Spirit of Prophecy." Rev. 19: 10. To have the Spirit of Prophecy, is to have the Spirit who uttered the prophecies and nor without the inspiration of the same Spirit. "For the prophecy came not in old time by the will of man: but holy men of God spake as they were moved by the Holy Ghost." (2 Pet. 1:20, 21), and consequently only holy men of God in the Spirit can interpret the Scriptures.

The testimony of Jesus Christ, Inspiration explains, is "the Spirit of Prophecy." Rev. 19: 10. To have the Spirit of Prophecy, is to have the Spirit who uttered the prophecies and nor without the inspiration of the same Spirit. "For the prophecy came not in old time by the will of man: but holy men of God spake as they were moved by the Holy Ghost." (2 Pet. 1:20, 21), and consequently only holy men of God in the Spirit can interpret the Scriptures.

Chapter 12 takes us even further back in time than chapter 11, way beyond the birth of Christ, then forward to the time the earth opens her mouth and swallows up the flood, and to the time of the remnant (the remnant are those who are left after the others are swallowed up by the earth). They as a people keep the commandments of God, and have the testimony of Jesus Christ. They are persecuted by the dragon immediately after the earth swallows up the flood.

Chapter 12 takes us even further back in time than chapter 11, way beyond the birth of Christ, then forward to the time the earth opens her mouth and swallows up the flood, and to the time of the remnant (the remnant are those who are left after the others are swallowed up by the earth). They as a people keep the commandments of God, and have the testimony of Jesus Christ. They are persecuted by the dragon immediately after the earth swallows up the flood.

to the end of the world, the time the kingdoms of the world "become the kingdoms of our Lord and His Christ." Verse 15.

Chapter 12 takes us even further back in time than chapter 11, way beyond the birth of Christ, then forward to the time the earth opens her mouth and swallows up the flood, and to the time of the remnant (the remnant are those who are left after the others are swallowed up by the earth). They as a people keep the commandments of God, and have the testimony of Jesus Christ. They are persecuted by the dragon immediately after the earth swallows up the flood.

Chapter 12 takes us even further back in time than chapter 11, way beyond the birth of Christ, then forward to the time the earth opens her mouth and swallows up the flood, and to the time of the remnant (the remnant are those who are left after the others are swallowed up by the earth). They as a people keep the commandments of God, and have the testimony of Jesus Christ. They are persecuted by the dragon immediately after the earth swallows up the flood.

Chapter 12 takes us even further back in time than chapter 11, way beyond the birth of Christ, then forward to the time the earth opens her mouth and swallows up the flood, and to the time of the remnant (the remnant are those who are left after the others are swallowed up by the earth). They as a people keep the commandments of God, and have the testimony of Jesus Christ. They are persecuted by the dragon immediately after the earth swallows up the flood.

Chapter 12 takes us even further back in time than chapter 11, way beyond the birth of Christ, then forward to the time the earth opens her mouth and swallows up the flood, and to the time of the remnant (the remnant are those who are left after the others are swallowed up by the earth). They as a people keep the commandments of God, and have the testimony of Jesus Christ. They are persecuted by the dragon immediately after the earth swallows up the flood.

Chapter 12 takes us even further back in time than chapter 11, way beyond the birth of Christ, then forward to the time the earth opens her mouth and swallows up the flood, and to the time of the remnant (the remnant are those who are left after the others are swallowed up by the earth). They as a people keep the commandments of God, and have the testimony of Jesus Christ. They are persecuted by the dragon immediately after the earth swallows up the flood.

Chapter 12 takes us even further back in time than chapter 11, way beyond the birth of Christ, then forward to the time the earth opens her mouth and swallows up the flood, and to the time of the remnant (the remnant are those who are left after the others are swallowed up by the earth). They as a people keep the commandments of God, and have the testimony of Jesus Christ. They are persecuted by the dragon immediately after the earth swallows up the flood.

Now, where does the seventh seal begin? First let us remember that the sixth seal brought us up to the end of the world. Obviously, therefore, the seventh seal, which covers a number of subjects, must overlap with the sixth. Let us note that the beginning of the seventh seal disclosed the Seven Trumpets.

The sixth seal contains the signs of the times and brings the end of the world. And since the sixth chapter of the Revelation brings us to the end of the world, and as the things of the seventh chapter take place before the end, it is obvious that the subject of chapter 7—the sealing of the 144,000 from the tribes of Israel, and the gathering of the great multitude from all nations (the first fruits from the church, and the second from the nations)—takes back into the period of the sixth seal. Besides, the seventh seal begins with chapter 8.

departed as a scroll when it is rolled together; and every mountain and island were moved out of their places. And the kings of the earth, and the great men, and the rich men, and the chief captains, and every free man, hid themselves in the dens and in the rocks of the mountains; and said to the mountains and rocks, Fall on us, and hide us from the face of Him that sitteth on the throne, and from the wrath of the Lamb: for the great day of His wrath is come; and who shall be able to stand?

What could the horses, driven by men, symbolize?—They can symbolize only something over which man rules, for a rider always rules that which he rides. The horsemen, then, must be symbolical of man's rule over the creation of God.

The colors of the horses and the professions of their riders show progress in greed and crime. It is evident from the symbolism that man's ruling the world has not wrought improvement.

The white horse denotes peace and purity which existed only at the beginning of the creation of God. By the rider of the white horse is seen man's great aim to subdue and to replenish the earth. And by the red horse and his rider we see blood-shed and wars. This brutality led the way for the black horse to come on the scene. The color black is significant of enslaving nations, and the balances are expressive of inventing commercial schemes to obtain wealth. The fourth horse, the pale, portrays a system of indefinable character—difficult to distinguish whether Christian or Pagan—hypocrisy. The fifth seal shows that the persecution of the saints continued to the opening of the sixth seal. Are not these the headlines of history? The Seals, therefore, begin with the commencement of these things.

Rev. 6:12-17—*And I beheld when He had opened the sixth seal, and, lo, there was a great earthquake; and the sun became black as sackcloth of hair, and the moon became as blood; and the stars of heaven fell unto the earth, even as a fig tree casteth her untimely figs, when she is shaken of a mighty wind. And the heaven*

The fourteenth chapter starts with the 144,000 standing with the Lamb on Mount Zion. Then follow the Three Angels' Messages in their direct and final application for the gathering of the second fruits. Thus the chapter closes with the harvest of the earth. The chapter itself shows that the harvest is in two sections, the first of which is reaped by the "Son of Man," and the second by an angel. Evidently these two harvests yield the first and the second fruits.

Chapter 13 begins with the dissolution of the Roman Empire, and with the kings who arose from it, who then took their crowns, as symbolized by the crowned horns of the leopard-like beast. This chapter ends with the two-horned beast's decree, the decree to kill all who dare not receive the mark of the beast. Thus will the dragon be wroth with the woman, and thus will he persecute the remnant.

When in time does chapter twelve begin? Well, it begins with the day the woman mentioned therein conceived the man child. Specifically speaking, her conception of the child points back to the time inspiration promised to send the Redeemer to the Church.

up by the earth, so to speak. This remnant will as a people be keeping the commandments of God, and be without guile in their mouths. They being the first fruits, inspiration thus points out that there is to be a second fruits, for without second there can be no first. And so we see that chapter 12 brings us to the time the church is purified, the time she as a church truly keeps the commandments of God.

Chapter 15 describes the events that bring probationary time to an end, and chapter 16 tells of the seven last plagues.

Chapter 17 begins with the rise of Babylon the Great and her dominion. Figuratively speaking, the scarlet-colored beast, the beast she drives, rules, is her dominion. This ecclesiastical world government develops after the leopard-like beast symbolization (chapter 13) ends its career, for the horns of the scarlet-colored beast are crownless, whereas the horns of the leopard-like are crowned. Its crowned horns show the world ruled by crowned kings, which already are about to pass away, and the scarlet-colored beast's crownless horns show a crownless world ruled by Babylon who rides the beast, rules it. This beast, says inspiration, "was and is not, and yet is." That is, he lived before the 1000 years, and therefore "was"; does not live during the 1000 years, and therefore "is not"; lives by resurrection after the millennium, and therefore "is."

He is the eighth and is of the seven; that is, Daniel's four beasts of chapter 7, and John's two of chapter 13, total six, the scarlet-colored of chapter 17 is therefore the seventh at the commencement of the millennium, and is the eighth after the millennium. Is of the seven because, as I said before, he is to die his first death at the commencement of the millennium, and in the resurrection after the millennium he lives again for a short period before he meets his second death, and that makes him the eighth in his second phase, and seventh in his first phase. Chapter 17 therefore begins with Babylon the Great mounting the beast, his first phase, and ends on the other side of the

We shall now kneel and pray that we may not forget that anything short of a sacrifice for religion and whole-hearted deeds can be the only evidence that the blood of Christ has done its work in us, and the only thing to ensure our right to the Holy City.

"This is the religion of Christ. Anything short of it is a deception. No mere theory of truth or profession of discipleship will save any soul. We do not belong to Christ unless we are His wholly. It is by half-heartedness in the Christian life that men become feeble in purpose and changeable in desire. The effort to serve both self and Christ makes one a stony-ground hearer, and he will not endure when the test comes upon him."

"If we love Jesus, we shall love to live for Him, to present our thank-offerings to Him, to labor for Him. The very labor will be light. For His sake we shall cover pain and toil and sacrifice. We shall sympathize with His longing for the salvation of men. We shall feel the same tender craving for souls that He has felt.

I shall read from page 49 of *Christ's Object Lessons*:

*Half-Hearted Religion
Causes Instability*

TEXT FOR PRAYER

The number seven in the Scriptures always carries the connotation of completeness. The Seven Trumpets therefore carry, as do the Seven Seals, a complete subject of their own. The term "trumpet" is significant of broadcasting a message. And so the Seven Trumpets in particular demonstrate the result which the disobedient to these messages suffered from the beginning to the end. That the seventh trumpet represents the last message is quickly seen from reading—

Rev. 11:15—*And the seventh angel sounded; and there were great voices in heaven, saying, The kingdoms of this world are become the kingdoms of our Lord, and of His Christ; and He shall reign for ever and ever.*

Here we see that the last message on earth is the message which announces the end of all earthly governments.

The Trumpets are in two divisions—the last three are "woe" Trumpets, the first four are not. That the Seven Trumpets cover both the Old and the New Testament times can easily be seen in a brief study of the fifth trumpet—

Rev. 9:1-4—*And the fifth angel sounded, and I saw a Star fall from heaven unto the earth: and to Him was given the key of the bottomless pit. And He opened the bottomless pit; and there arose a smoke out of the pit, as the smoke of a great furnace; and the sun and the air were darkened by reason of the smoke of the pit. And there came out of the smoke locusts upon the earth: and unto them was given power, as the scorpions of the earth have power. And it was commanded them that they should not hurt the grass of the earth, neither any green thing,*

Now I would have you note that The Revelation contains several subjects, each of which is complete in itself, although one chapter or subject may overlap or intercept the others; that is, not all the subjects and chapters are in chronological arrangement with one another.

In these studies we have also learned that the event which caused the book with the Seven Seals to be opened, disclosed The Revelation itself, and that strictly speaking, "The Revelation of Jesus Christ which God gave unto Him" begins with chapter 6 and ends with chapter 22—seventeen chapters in all, which the breaking of the Seals disclosed. We also learned that the things that were to be "hereafter" from Saint John's time, after 96 A.D., were those things which the event brought forth, the great assembly itself round about the Throne having met to examine the things that were inside the Book.

Our past studies have shown that all the books of the Bible meet and end in The Revelation (*Acts of the Apostles*, p. 585); that The Revelation covers the entire history of mankind.

*Text of Address by V. T. Houteff,
Minister of D. Seventh-day Adventists
Sabbath, November 8, 1947
Mt. Carmel Chapel
Waco, Texas*

THE SUMMARY
REVELATION CHAPTER BY CHAPTER—
THE CHRONOLOGICAL SETTING OF THE

what the cloud and the rainbow signify). He also caused the little book to be eaten (taken to heart), which later became bitter inside the eater.

The honey sweetness while the book was being eaten obviously denotes that the things written therein were joyously received. But to the eater of the book it later caused indigestion, so to speak, and thus a disappointment; that is, the things in the book were not fully comprehended, and thus in the end the joy vanished away, and disappointment crept in. After this, the book eaters were commissioned to "prophesy again," to preach again.

This angel in the stream of time, therefore, appears at the unsealing of the book of Daniel, for it is the only book of the Bible that was ever sealed, and never to be opened from the time it was written to "the time of the end."

The subject of chapter 10 ends with the second verse of chapter eleven, the verse which brings us to the time of the measuring (numbering) of the people, which obviously is the numbering of the 144,000 (chapter 7:3-8), for they are the only numbered company of people in the thread of prophecy. Thus it is that chapter ten, including verses 1 and 2 from chapter 11, begins at "the time of the end," and ends with the numbering of the 144,000.

The eleventh chapter (save for the first two verses which chronologically belong to the tenth chapter) goes still further back in time than does the tenth chapter. It contains the subject of the two witnesses who prophesied during the 1260 prophetic days. It, too, brings us forward

We have now seen the nature and time where the Seven Seals and the Seven Trumpets begin and all their details can do so by studying the tracts,—"The Final Warning," and "The Breaking of the Seals,"—which will be mailed free upon request.

Now the plain fact that the Christian era began with the sounding of the fifth Trumpet, the truth of the first four Trumpets must be sought in the Old Testament era.

Here you have it in Inspiration's own code of mysticism, freshly unveiled that Jesus Christ is indeed a heaven-sent Being, the Saviour of the world.

Rev. 4:18, 19—*The Spirit of the Lord is upon Me, because He hath anointed Me to preach the gospel to the poor; He hath sent Me to heal the broken-hearted, to preach deliverance to the blind, to set at liberty them that are bruised, to preach the acceptable year of the Lord.*

neither any tree; but only those men which have not the seal of God in their foreheads.

To the Star which came down from heaven is applied the masculine pronoun "He". To Him the key of the bottomless pit was given. Whom could the Star symbolize?—Let us turn to Revelation 20:1—

Rev. 20:1—*And I saw an angel come down from heaven, having the key of the bottomless pit and a great chain in His hand.*

Here we are told that this mighty angel, Satan's enemy, has the "key of the bottomless pit." If He has it, then to Him the key must have been "given." The Star that received the key, therefore, is symbolical of this angel.

Moreover, let us notice that as the key opened the bottomless pit, the locusts were released. Finally, the fact that the locusts are enemies to those who have not the seal of God in their foreheads, then the "Star" (angel) that came from heaven and opened the pit to release the locusts is a friend to them and a mighty enemy to Satan. There is therefore no escaping this conclusion: The heavenly Star represents a heaven-sent Being, the same "angel," of Whom we again read in chapter 20:1, and the locusts are Heaven's rescued multitude. Who else, then, can the "Star" and the locusts represent but Christ and the Christians? Satan had shut up into the bottomless pit the entire Jewish nation,—the only nation that had previously been out of the pit. Christ therefore came to open the pit and to let the captives go free. To such a world was the Lord of Heaven sent, and when He came He immediately declared:

Chapter 8, the opening of the seventh seal, begins by introducing another subject, the subject of the Seven Trumpets. The Trumpets as we

The seventh chapter begins with the sealing of the 144,000, and ends with the gathering of the great multitude, touching eternally.

Since chapter six ends its story with the end of the world, it is obvious that chronological-ally chapter seven is sandwiched between the event with which chapter six begins, and the event with which it ends.

Rev. 6:14-17—*And the heaven departed as a scroll when it is rolled together; and every mountain and island were moved out of their places. And the kings of the earth, and the great men, and the mighty men, and every bondman, and every free man, hid themselves in the dens and in the rocks of the mountains; and said to the mountains and rocks, Fall on us, and hide us from the face of Him that sitteth on the throne, and from the wrath of the Lamb: for the great day of His wrath is come; and who shall be able to stand?*

We previously found that the judicial-like event opened with the Revelation of Jesus Christ which God gave unto Him, the Book sealed with the seven seals. It disclosed the Revelation, and with it the heavenly assembly began its work of reviewing the past, present, and future of mankind. We shall now read the closing verses of chapter six—

These facts shall be shown as we proceed in our study.

learned in our previous studies spread through chapters 9 to 11.

We further learned that the Trumpets disclose the messages of God and the consequences to the unrepentant sinners; that the Trumpets begin with the first such message, the message of Noah, and end with the last message in probationary time, the message which announces that the Mystery of God, the Gospel work, is finished, that probationary time is at an end. This is further seen from the fact that the rest of the men who were not killed by the fire, smoke, and brimstone which came out of the horses' mouths (Rev. 9:18) repented not. Indeed, it could not be said, "They repented not," if their time of repentance had not passed. Thus it is that chapters 8 and 9 bring us to the close of probation. Chapters 10 and 11 consequently sandwich in chapters 8 and 9.

The Trumpets themselves are shown to be in two divisions, four in the Old Testament time, and three in the New; that is, the last three are "woe" Trumpets. The first of the woe Trumpets introduces the descending of the heavenly Star to Whom the key of the bottomless pit was given. Obviously the Star is symbolical of the Angel who at the commencement of the millennium shuts Satan into the bottomless pit, for He, the Angel of Revelation 20:1, is the Angel Who has the key of the bottomless pit. He could not possibly have the key if it had been given to some other.

Chapter 10 discloses that the angel who opened (unsealed) the "little book" is the angel who brings the spiritual rain for the developing and ripening of the spiritual grain (for that is